



Road Haulage of Round Timber

Code of Practice



TimberTransportForum

delivering solutions for a growing UK harvest

Road Haulage of Round Timber Code of Practice

4th Edition

© Copyright 2012

First published by the Timber Transport Forum in 1996. This new fourth edition published in 2012.

ISBN 978-0-85538-858-4

Timber Transport Forum (2012).
Road Haulage of Round Timber Code of Practice
(4th Edition). Timber Transport Forum. i-iv + 1-28 pp.

Keywords: Road haulage; Round timber; Safety, Sustainability; Timber transport.

FCMS027/FC-GB(MMJ)/JTCP-3K/MAR12

Enquiries relating to this publication should be addressed to the Timber Transport Forum.
Contact details can be found at www.timbertransportforum.co.uk



Preface	iv
1. Introduction	1
1.1 Background	1
1.2 The aim	1
2. Vehicle specifications	3
2.1 Specifications for timber transport vehicles	3
2.2 Load-weighing devices	3
2.3 Overloading (vehicle)	4
2.4 Reduced ground pressure vehicles	4
3. Roads network	6
3.1 Forest roads	6
3.2 Overloading (road damage)	8
3.3 Roadside facilities	8
3.4 Road defect reporting	9
3.5 Agreed Routes	9
3.6 Extraction and timber stacks	10
4. Loading timber	12
4.1 Safety	12
4.2 Safe loading	14
4.3 Security of loads	15
4.4 Preventing water and ground pollution	18
5. Transporting timber	19
5.1 Route planning	19
5.2 Driving	20
5.3 Efficient driving	20
6. Unloading timber	21
7. Improving roundwood haulage	23
7.1 Continuous improvement and co-operation	23
7.2 Communication	23
7.3 Training	23
7.4 Biosecurity	24
Supporting documents	25
Appendix 1	26
A1.1 Maximum weights for artics and drawbar combinations	26
A1.2 Maximum weight for rigids	26
A1.3 Maximum overall lengths	27
Appendix 2	28
A2.1 Effective signs for forest operations	28
Example road defect report	

Preface

The Timber Transport Forum has prepared this 4th edition of the Code of Practice to provide a general statement of the legal and technical issues relating to the road haulage of round timber in Great Britain. The Code of Practice has no legal status, and while care has been taken in preparing this edition, it does not cover every issue, or provide detailed guidance on specific problems.

The Code of Practice has been endorsed by:

- Association of Chief Police Officers of Scotland
- VOSA (Vehicle Operator and Services Agency)
- The Scottish Government
- Health and Safety Executive
- The constituent bodies of the Timber Transport Forum

The Timber Transport Forum is a voluntary partnership that brings together representatives of local government, central government agencies and the timber industry to support the many regional timber transport groups from northern England, Scotland and Wales. See www.timbertransportforum.org.uk for more information.

The Code of Practice is primarily written for those directly involved, or who have an interest in the transportation of timber and management of timber haulage. The Code is not a 'stand alone' document. It does not cover basic aspects of Large Goods Vehicle (LGV) driving or Department for Transport (DfT) standards, nor does it comprehensively cover health and safety in timber haulage. It is advised that you also consult:

- Drivers' Handbook – Freight Transport Association (FTA) www.fta.co.uk
- Drivers' Handbook – Road Haulage Association (RHA) www.rha.uk.net
- Managing Health and Safety in Forestry www.hse.gov.uk
- Code of Practice – Safety of Loads on Vehicles (DfT) www.dft.gov.uk
- Rural Driving Guide – Freight Best Practice www.transportscotland.gov.uk/road
- SAFED for HGVs – Freight Best Practice www.transportscotland.gov.uk/road

All sectors of the transport chain have individual responsibilities for making sure that they and others follow this Code of Practice.

1. Introduction

1.1 Background

Road transport is the single most important means of timber transport in Britain and over 90% of all timber is delivered to processing plants by lorry. Timber transport costs are a substantial part of our industry's raw material costs and have a major influence on the sector's overall competitiveness. Developing a safe and efficient timber transport system is therefore essential to the continued success of the forest industry.

Road haulage will remain the dominant form of timber transport. Even for rail, waterway and marine modes of transport, the first leg of the journey out of the forest will normally need to be by lorry.



Lorry loading operations underway in the forest.

Developing the necessary infrastructure for timber transport in Great Britain is not easy. The volume of timber produced each year from British forests is forecast to rise from the current 9 million cubic metres to 12 million cubic metres by 2020. The specific issues we need to address include:

- making sure timber is transported safely and efficiently;
- ensuring the suitability of roads that will be used for timber transport;
- minimising the impact of timber transport on local communities;
- investing more in facilities to increase the use of rail and sea transport.

The forest industry has risen to this challenge; in recent years we have removed many of the barriers to timber transport, and we will continue this work over the coming years. One of the most significant achievements to date has been setting basic standards for road haulage. The Code of Practice was first published in 1996 and revised in 1998 and 2002. It is hoped that this revised (4th edition) of the Code of Practice will lead to further improvements in timber transport.

1.2 The aim

The aim of this Code of Practice is to improve the efficiency, safety and environmental standards of timber transport.

To achieve this aim, the timber industry will need to:

- Make sufficient resources available for the management of health and safety in haulage to ensure drivers can work safely. This will also help other road users.
- Have significant research, development, resources and outputs to improve productivity and reduce the costs of road haulage.
- Develop logistic control systems for better navigation, improved communication and reduced empty driving. These systems also add value to the entire timber supply chain by improving management.
- Invest in specific facilities to improve haulage conditions at processing facilities, railheads and ports.
- Co-operate with regional and local authorities to direct timber traffic to the most appropriate roads.
- Work with local communities to explore and resolve timber traffic problems.
- Continuously improve the environmental standard of timber transport.

2. Vehicle specifications

2.1 Specifications for timber transport vehicles

An overview of the different vehicle types and their specifications is given in Appendix 1. This information is based on the Road Vehicle (Construction and Use) Regulations 1986 – SI 1986 No. 1078.

It is the responsibility of the landowner and forestry works manager, together with the vehicle operator, to agree the vehicle configuration, design and specification suitable for the work.

2.2 Load-weighing devices

The legal requirement for vehicle and axle weights to be restricted is very clear and there is no doubt when a driver has committed an offence. The method of assessing vehicle and axle weight by VOSA (Vehicle Operator and Services Agency) and the Police is generally to use weighbridges. The Law may allow a defence against penalty for a weight offence on the grounds that the vehicle was going to the nearest available weighbridge. Owing to the dispersed nature of the forestry industry, travelling to the 'nearest available weighbridge' is not always practicable and, if during that journey, the vehicle is overweight, damage may occur to both forest and public roads.

All road vehicles used for transporting roundwood on forest and public roads within Great Britain must have access to a weighing device which, from the point of loading within the forest, shows the gross vehicle weight or load weight. The device may be on the vehicle, or on the machine loading the vehicle. The operator must be able to produce a document recording this information. Operators will provide this record on reasonable request to the Landowner, VOSA, Police, Department for Transport, Health and Safety Executive and mill personnel. **You should not engage hauliers unless they have access to this equipment.**



Load weighing devices may be fitted to lorry-mounted loaders.

A number of manufacturers provide load cells for haulage vehicles or devices for fitting to loaders, which can provide an approximate record of the vehicle, gross weight or load, and some also provide an axle weight record. There are also varying types of mobile weighbridges available that provide similar information.

2.3 Overloading (vehicle)

Overloaded vehicles can impact on road safety and can cause road damage. All parties responsible within the supply chain have a duty to monitor compliance with Gross Vehicle Weights: **Overloading is illegal.**

You should:

- Tell hauliers if they have exceeded prescribed weight limits.
- Restrict payment for any load to the legal capacity of the vehicle.
- Decide on a penalty system for non-compliance.

To monitor that a haulier is complying with Gross Vehicle Weights (GVW), it is recommended that a check is made of a sample of weight tickets. Bear in mind the limitations of weighing devices.

2.4 Reduced ground pressure vehicles

A range of reduced ground pressure vehicles has been trialled and used in forestry operations. Tyre pressure control systems, (also referred to as Central or Variable tyre inflation systems) are being fitted to some timber lorries, trailers and articulated vehicles. These enable the driver to adjust the tyre pressure on the drive and trailer axles to suit the load and road conditions. They have been proven to improve traction and to help reduce the impact of haulage on unsealed and minor public roads (an unsealed road does not have a bituminous surface). On some trailers, twin tyres are being replaced with a 'maxi super single' tyre. Tyre pressure control systems in timber transport are the subject of a Freight Best Practice publication.

Some companies use bespoke low ground pressure vehicles on weak forest and public roads. Roundwood is then transferred to road vehicles, rail wagons or coastal shipping for onward haulage.

Tyre pressure control systems fitted to timber lorries can help reduce the impact on fragile roads.





This bespoke low ground pressure timber trailer and tractor combination spreads the weight of the load across the road.

REMEMBER

- ✓ Use the correct vehicle configuration for the forest road.
- ✓ Overloading damages roads.
- ✓ Overloading is illegal.
- ✓ Continually monitor gross vehicle weights.
- ✓ Maximum gross weight restrictions refer to a vehicle's legal loaded limit, unless otherwise stated.

3. Roads network

3.1 Forest roads

Forest roads are usually single-track with passing places. They are also usually unsealed. Because of this construction, forest roads are more susceptible to surface effects such as potholes and corrugations, than roads with a bituminous surface and higher vehicle speeds can increase surface damage.

The landowner or their legal appointee has the responsibility for:

- Providing a safe means of site access and exit. This could include using warning signs and improving sight-lines at access points.
- Providing a forest access road capable of safely carrying vehicles of the configuration agreed before haulage contracts start.
- Providing the haulier with a map, either directly or through the forestry works manager, that shows any hazards and restrictions which could affect haulage.
- Providing an advisory speed limit to all vehicles operating on their property.

The landowner should:

- Make sure the forest road is well maintained with an adequate running width and passing places.
- Provide the haulier with a map, either directly, or through the forestry work manager, that shows recommended routes and the limitations of the site for large goods vehicles.

New forest roads should be designed to take account of a presumed loading and other factors based upon vehicle specifications. A reasonable design specification would take into account:

Loading – based on the current Construction and Use Regulations covering maximum normal size of vehicle.

Timber lorry on a purpose-made unsealed timber haul road.



Width – usually 3.4 m, but wider where required to account for roadside stacking and/or loading facilities.

Gradient – generally limited to 10% except in particular circumstances for limited lengths.

Bends – minimum bend radius with appropriate bend widening, and perhaps restricted gradients.



An on-site stone crusher provides material for constructing this forest road on Mull.

A major factor will always be the material used for the construction of the road. Any weaknesses in the material can usually be allowed for in the design.

Roads are weaker when wet. This is particularly true of unsealed roads compared with sealed roads. Forest roads should be designed and maintained so that water can drain freely away from the road structure. This is best achieved by making sure that:

- overhanging trees and encroaching vegetation are removed to promote drying of the road;
- drains remain free flowing;
- culverts are not blocked;
- harvesting operations do not bring mud and debris onto the road allowing water to pond and seep into the road structure;
- harvesting machines do not damage the road surface allowing a route for water ingress;
- the use of traction aids, such as wheel chains and tracks, is limited on forest roads;
- rutting is dealt with before it seriously contributes to water retention.

Some of this can be difficult to achieve at any time of the year, but it is particularly difficult in winter. Unsealed roads are also susceptible to frost heave and can suffer serious damage if used during periods of thaw. Particular care must be taken to protect forest roads in winter conditions – roads may be closed during periods of icing and thawing to protect their structure. Salt should never be applied to an unsealed road.

Everyone has a role to play to ensure that the road will continue to be fit for purpose.

3.2 Overloading (road damage)

Roads are significant financial assets, and damage to them through overloading must be avoided.

The graph below shows the increased damage due to overloading of a 3+3 combination (see Appendix 1) that can legally operate at 44 tonnes GVW.

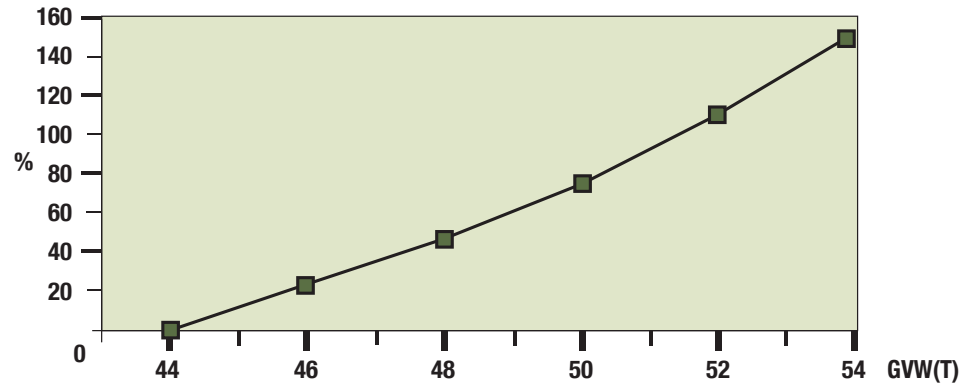

If the load increases beyond the design load of the road, this can have a significant effect. In particular, the practice of lifting axles to increase the traction of the drive axles can not only lead to significant overloading of the other axles, perhaps outside the vehicle's design limits, but can also lead to even greater damage to the road than shown above. It is in everyone's interest to work together to make sure that there is no need for a driver to even consider lifting an axle. Tyre pressure control systems fitted to drive axles can help improve traction.

3.3 Roadside facilities

Forest road design must also take account of timber extraction and stacking operations. Timber has to be brought to roadside for loading onto road vehicles. Due to the width and structure of a normal forest road, some extra roadside facilities such as loading bays, will normally be provided. The number and type of these will depend on the rate and method of extraction and this should be agreed in advance of work starting so that any construction work can be completed.

Roadside facilities can help safe extraction, stacking and timber loading, while protecting the road. Facilities could include:

- additional tracks to keep harvesting machines off the road (where possible);
- ramps to allow safe access to felling site;
- stacking or loading places on clear, flat ground;
- trailer parking bays;
- skyline bases;
- silt traps and other controls to avoid environmental damage and pollution;
- adequate turning areas for lorries;
- a one-way system to minimise reversing (where possible);
- passing places;
- parking places for site staff.

Careful consideration of the need for and siting of roadside facilities will help the safe and efficient loading of stacked timber.

3.4 Road defect reporting

Dealing promptly with road defects is important, especially as some forest roads are being used more heavily than in the past. It is important to be clear about what constitutes a 'defect'. Unsealed roads are subject to potholing, rutting and corrugations, as well as to accumulations of loose material – this is normal. However, as these features worsen they will, at the very least, hinder operations and slow other road users. In these circumstances, agreement will be required on when to intervene.

It is the responsibility of all road users to report defects early – before the defect has become serious enough to make using the road unsafe. If a written record is required, an example form is provided on the inside back cover.

Everyone involved in a harvesting or haulage operation should be aware of a road defect reporting system, set up as part of the contract. The procedure must make clear:

- where and who to report to;
- the information required;
- how replies are handled;
- the responsibilities of the landowner, forestry works manager, contractor and sub-contractor.

This does not mean that a road will receive an immediate repair, but it does put into practice a system where the road can be assessed and repairs carried out promptly. In some instances, the landowner may reserve the right to close the road or provide an alternative route.

All road defects should be repaired using the most appropriate materials to make sure the repair lasts.

3.5 Agreed Routes

Local authorities are responsible for providing and maintaining an adequate rural road network. The condition and strength of public roads in rural areas is variable. The forest industry has liaised with various local authorities to agree which public roads to use for transporting timber from the forests to the main public roads. This has led to a system of Agreed Routes being set up in many areas. This process allows questions of road and environmental damage, and community and safety issues to be addressed and to enable local authorities to target their resources effectively.

If there is not an Agreed Routes scheme in a particular area, liaison with the local authority and other interested parties to discuss and agree a preferred route for the proposed contract is recommended.

You should make hauliers aware of any Agreed Routes and make sure they use them. Failure to do so could result in further restrictions being imposed by the local authority.

Agreed routes maps show the preferred route for timber haulage. They also identify roads where the local authority should be consulted before their use for timber haulage.

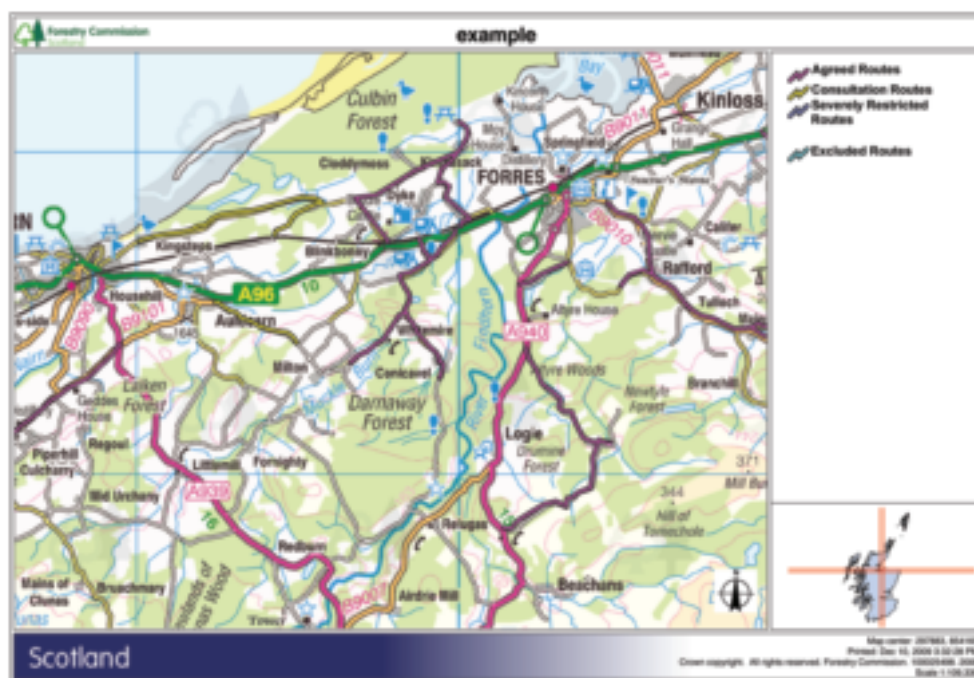

3.6 Extraction and timber stacks

Hazards to timber haulage must be considered when producing the harvesting site plan and site safety rules. The controls devised must be clearly stated in the site-specific risk assessment. Extraction points on forest roads should be located to reduce risks in both extraction and haulage. Hazards identified in the site plan should be clearly described and site safety rules provided to the haulier and drivers.

Extracted timber must be stacked safely to make loading safe and straightforward. The following points represent good practice:

- Timber should be stacked at a safe distance from the road, but still easily accessible to the lorry.
- Stacks should not be more than 2 metres high, unless specifically covered by a risk assessment.
- Designated passing points and turning places should not be obstructed by timber, vehicles or equipment.
- The stack face on the road edge should be flush; the profile should not have steep slopes.
- Ideally, the stacks should be placed on even ground and not between growing trees or rocks.
- If the ground is not firm and there is a risk of the stack collapsing, use bearers under the stack and monitor stack conditions, reacting as necessary to any significant change.
- The stacks should be free from branches, stones and other material.
- Stacks should allow water to drain away.
- Site stacks should be located away from overhead and underground power lines.
- Stacks should be located so they do not obstruct sight-lines around corners in the road.
- If timber has to be stacked on slopes, ensure stacks are positioned to allow the lorry to load facing downhill.

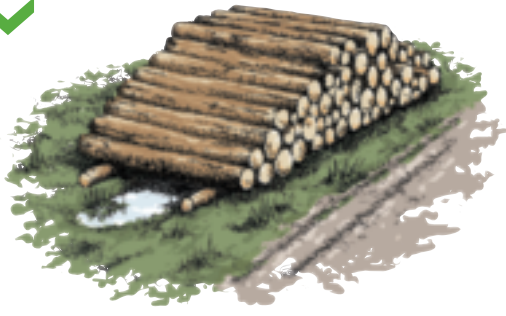

Logs on bearers



Logs stacked in water



Logs correctly stacked



Logs stacked over ditch



Logs correctly stacked



Roughly stacked logs

REMEMBER

- ✓ Use Agreed Routes.
- ✓ Avoid road abuse.
- ✓ Report road defects.
- ✓ Plan the loading site.
- ✓ Stack timber safely.
- ✓ Issue site safety rules to drivers.

4. Loading timber

4.1 Safety

4.1.1 Public safety

To make sure the public are safe, a risk assessment process should be undertaken. Safety signage may be required to warn the public of operations and barriers should be used if necessary. For an example of effective signs used in forest operations please refer to Appendix 2. Consider fitting and using reversing warning signals or flashing beacons if vehicles are working in areas regularly accessed by the public.

4.1.2 Driver safety

Drivers should comply with the site safety rules, which should also specify the personal protective equipment (PPE) that they must wear. If loading is done by others, the site safety rules should state where the vehicle driver should be while timber is being loaded.

A procedure for lone-working will be required. Always encourage drivers to report their position while working off the public highway. If there is an accident while working alone, a swift rescue response could very well save a life.

Safe working practices must be followed, appropriate to the remote location of many forest sites.



Drivers should carry a suitably stocked first aid kit in their cab at all times. They should be trained in how to provide first aid response to typical injuries and incidents. First aid training can be via Driver CPC (See section 7.3.1) or via HSE-approved first aid courses. You can find more information on first aid on the HSE website at www.hse.gov.uk.

4.1.3 Safety during vehicle recovery

Lorry and plant recovery operations are high risk and often require specialist equipment which is tested, certified and operated by experts. What may seem a simple recovery can quickly become complicated, risking serious injury to those involved. Everyone involved in vehicle recovery must be trained, use the correct equipment and be aware of specific risk assessments.

You can find more information in AFAG Guide 703 Debugging and Recovery of Forestry Machines at www.hse.gov.uk/pubns/forindex.htm.

4.1.4 Load shedding and overturning

Hauliers must make sure that timber has been properly loaded and that adequate load restraints are used. Keeping to the correct speeds for the road and weather conditions will reduce the likelihood of shedding a load – see Section 4.3. While driving on single track roads, wheels should not leave the tar macadam surface, which can cause damage to the road and verge. In most cases the verge will not support the weight of the vehicle and there is a risk of overturning.

The haulier should:

- keep to the legal or recommended speed limit at all times;
- drive appropriately for weather and road conditions;
- avoid uneven loading of the vehicle;
- observe gross vehicle weights;
- use the available road space responsibly – keeping wheels away from hazardous or soft ground.

4.1.5 Collision

Several actions can help to minimise the risk of collisions. The landowner and forestry works manager should:

- tell the haulier about other road users they can expect while working in the forest;
- where possible, select routes to minimise the risk of collision with other road users, for example, by using one-way systems if appropriate;
- make sure there are enough operational signs (see Appendix 2);
- make sure, where practicable, there is good visibility and adequate sightlines around corners;
- make sure stacks of timber are positioned so they do not compromise sightlines;
- make sure that there are enough passing places.

The haulier should:

- observe the speed limits set by the landowner;
- park vehicles so they do not hinder operations and other road users;
- drive to suit the prevailing conditions;
- be aware of other road users.

4.1.6 Adverse weather

Bad weather can increase hazards to road haulage and be a contributory factor in accidents. The landowner and forestry works manager are responsible for deciding whether the forest roads should remain open or be closed during extreme weather. However, the final decision on whether the road is safe to use rests with the driver.

As forest roads are particularly fragile during periods of frost and thaw, the landowner or forestry works manager may decide to restrict road access during this time. Unsealed roads may be treated with grit or sand, but never salt, as this will damage the road structure. Where possible, schedule work for the seasons of 'better' weather. This will reduce the need for road closures and restricting access.

4.2 Safe loading

It is important that vehicles are loaded safely to avoid injury to the operator, the public or other third parties.

The following points represent good practice:

- A site risk assessment should be carried out before work starts – more information can be found at www.hse.gov.uk.
- Drivers must comply with the site safety rules.
- Personal protective equipment should be worn as detailed in the site safety rules.
- Training or instruction to drivers should be provided where required and their work monitored to ensure safe practice during loading operations.
- Loading and unloading should be planned to minimise working at heights – more information can be found at www.hse.gov.uk.
- There should be enough signs during the loading operation to warn others of the hazards.
- Compliance with the site safety rules should be monitored.
- The loader and associated equipment must be maintained to minimise the possibility of failure and comply with Lifting Operations and Lifting Equipment Regulations (LOLER) and Provision and Use of Work Equipment Regulations (PUWER) Legislation.
- The haulier must make sure all operators are aware of the maximum loads for each piece of equipment.
- Where trailers are left in the forest for later loading, the landing legs on the trailer should be positioned on a suitable bearer.
- Stacks must be left safe and stable after loading.

Several factors may present hazards during loading and driving in the forest, for example powerlines and road failure.

4.2.1 Power lines

'Goal posts' should be used where there are overhead power lines within a forest site.



Overhead power lines are a hazard for vehicles, especially during loading. When the loader arm is raised it can 'earth' electricity from a line without actually touching it, particularly in damp weather. Site planning by the landowner and forestry work manager is particularly important to make sure the areas set aside for loading are a safe distance from power lines. The landowner must have signs in place showing the

position of power lines, and the maximum height of equipment that can safely pass under lines must be clearly marked. 'Goalposts' should be used where there is a power line within a harvesting site (see AFAG Guide 804 *Electricity at work: forestry and arboriculture* www.hse.gov.uk/pubns/forindex.htm).

Signs and goalposts must be maintained throughout the operations and moved as necessary. Where civil engineering works alter road levels, make sure that safe clearances are maintained.

Underground power lines may also be a hazard in areas such as wind farms, where liaison with the electricity company will be required.

Drivers must not move off unless the lorry-mounted loader is properly stowed.

4.2.2 Road failure

Road inspection and defect reporting are the first steps in minimising failure to which all road users can contribute. During the loading operation there are several factors that the haulier needs to consider and which are their responsibility.

- **Correct loading of the vehicle.** Axle weights must be considered when positioning the load. Uneven loading of a large goods vehicle will increase the load on certain axles rather than equalise the load over all the axles.
- **The position of the vehicle on the road.** Where practicable, position the vehicle away from the edges of the road, particularly on unsealed forest roads as the edges are not physically restrained and are more likely to fail.

Where required, use load-spreaders under outriggers to reduce damage.

4.3 Security of loads

The legal requirements for load restraint are contained in the Road Vehicles (Construction and Use) Regulations and the Road Traffic Acts.

The Department for Transport (DfT) issued advice in a Code of Practice (October 2002) on the *Safety of Loads on Vehicles* and the relevant advice includes the following points:

4.3.1 Headboards

- Where headboards are fitted as part of load restraint systems, make sure they are properly maintained.
- The headboard should be high enough to stop the load moving forward.
- Where there is no headboard, additional restraints will be needed to stop the full load moving forward.

4.3.2 Straps and anchorage points

This section provides recommendations for the minimum standards to secure roundwood loads on road vehicles. The driver is ultimately responsible for making sure that the load is safe and secure. So, in certain circumstances, the driver may decide that additional restraints are required.

The driver is responsible for making sure the load is safe and secure.



- The load restraint system must be sufficient to stop the total weight of the load moving forwards under severe braking, and enough to withstand a force equivalent to half the weight moving backwards and sideways.
- Do not load timber to a height, or in such a way, to make either the vehicle or load unstable.
- Whenever possible place the load against the headboard or similar fixed restraint.
- Load straps or chains are recommended, rather than ropes.
- Calculate the number of load straps required for a particular application using the Rated Assembly Strength (RAS). Although the load strap may be rated at five tonnes breaking strain, it will have an RAS of 2.5 tonnes.
- For vehicles fitted with cab-height headboards, secure each bay or bunk of roundwood with at least one correctly rated strap.
- For vehicles fitted with both front-mounted timber loaders and timber specific (aggressive) bolsters, secure the load with one correctly rated strap per bay/bunk.
- All vehicles not fitted with a cab-height headboard should have the bay or bunk nearest the cab secured with two correctly rated straps. Secure all other bays or bunks with at least one appropriately rated strap.
- Secure all de-barked (bark removed) roundwood loads, irrespective of vehicle type or configuration, using a minimum of two appropriately rated straps for each bay or bunk.
- Check the load and load straps before moving from the forest road to public road, and during the journey if necessary.
- Monitor the condition of straps, chains and bolsters and replace damaged items.

4.3.3 Securing lorry mounted timber loaders

Under normal circumstances, the boom or jib of the loader should be bedded into a 'valley' or 'trough' created in the top of the roundwood load and strapped in position. In this case, it is not considered necessary to strap the load and the boom separately. However, if for capacity reasons, it is necessary to build the load level with the top of the bolsters the load should be strapped independently of the boom or jib, which should be strapped separately, to ensure adequate load restraint.

4.3.4 Longitudinal loading

Restrain each outer log by at least two upright supports. Place logs that are shorter than the distance between two uprights inside the load.

- The upright supports should be strong enough to prevent the load spreading them apart.
- Where logs are supported by only two uprights, the ends of the outer logs should extend at least 300 mm (12 inches) beyond the uprights.

- Preferably lay logs top to tail to ensure an even balance of the load.
- For debarked roundwood, and for any timber that is slippery, use at least two load straps per bay.

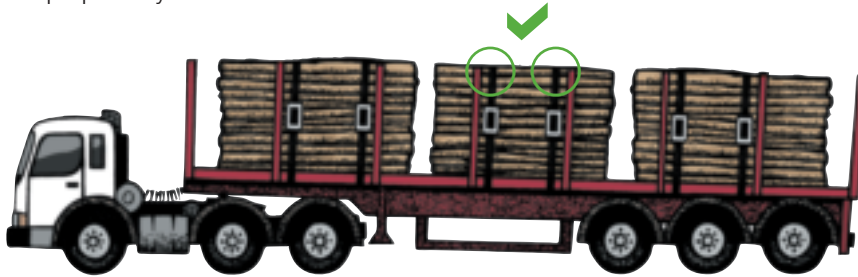

- Secure load straps to the vehicle frame and tension them with a suitable device.
- The centre of each top outside log must be no higher than the inside logs that crown the load and enable it to be properly tensioned by the load straps.
- Any rear projection of loads that are between one and two metres must be marked to make them visible to other road users (See section Appendix 1 for overhanging load requirements).



4.3.5 Transverse loading

Industry research and the incidence of shed loads have clearly shown that transverse (cross) loading is dangerous. Timber cannot be adequately secured stacked across a flat-bed vehicle using conventional restraints. If timber is carried in this way, then suitable side gates must be used. Do not load higher than the side gates.

Passing straps or chains from the front of the vehicle across the top of the timber to the rear with cross straps is not acceptable.

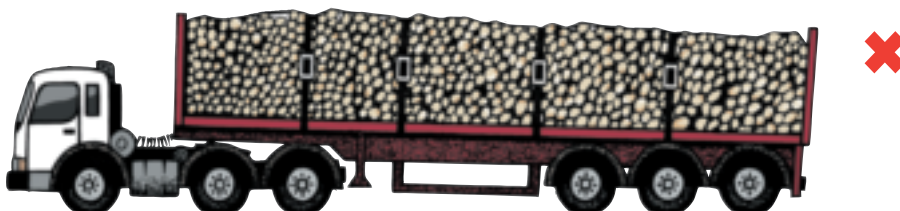

4.3.6 General advice

- Load the vehicle to facilitate unloading at the delivery point; for example have the correct clearance between pins and do not have interlocking bays.
- Check the height of the loaded vehicle to make sure that it will pass under any obstruction likely to met on route.
- Make sure headboards, (where fitted), bolsters and uprights are securely fixed to the vehicle frame.
- Pins and bolsters should be fit for purpose. Pins should not spread beyond the width of the trailer when loaded.
- Do not use loose bolsters.
- Inspect and maintain all load securing equipment.
- The vehicle operator is responsible for providing suitable load securing equipment for each load carried and for making sure that drivers or loading staff are competent and trained to use it.
- **The driver is responsible at all times for ensuring that the load is secure.**

Pins should not spread beyond the width of the trailer.

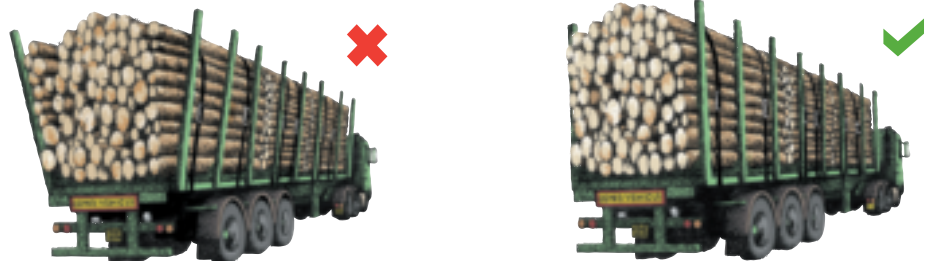

4.4 Preventing water and ground pollution

The forest industry is striving to reduce the impact of the transport chain on the environment. Drivers must be aware of the consequences of fuel or oil spills, and who to contact if there is a pollution incident. All vehicles must have a pollution control kit.

The UK Forestry Standard Guidelines on *Forests and Water* (www.forestry.gov.uk/ukfs/water) is the accepted standard for all work in the forest which could affect water quality. Use the guidelines in this document in risk assessments, and refer to them in contracts. Drivers should be made aware of them, and be in no doubt about the action that they must take if there is any accidental breach of the UKFS and a danger of polluting watercourses. The penalties that can be imposed by the Environment Agency (for England and Wales), and the Scottish Environment Protection Agency are severe. Adhering to the Forests and Water guidelines may assist a defence in the event of an incident. The following points represent good practice:

- Clean the loading site immediately after loading operations have been completed.
- Do not leave any rubbish at the work site.
- Avoid carrying mud and debris from the forest onto the public road.

REMEMBER

- ✓ Secure the load.
- ✓ Carry a pollution control kit and know how to use it.
- ✓ Be aware of hazards.

5. Transporting timber

5.1 Route planning

Drivers and hauliers, as well as those who engage hauliers and logistics managers, should follow good practice by:

- Selecting the best route in terms of length, time, safety, community impacts and road restrictions.
- Planning the route to minimise empty driving.
- Planning operations to minimise the frequency of vehicle movements on a particular route, by spreading large orders across several sites or forests or by stockpiling timber in advance at a pierhead.
- Avoiding convoys of timber vehicles on forest and public roads.
- Co-operating with other operators to reduce overlapping transport operations.



Stockpiling timber at a pier head prior to the arrival of the ship can reduce the frequency of vehicle movements when the ship arrives.

5.1.1 Road limitations and restrictions

Road specifications and maintenance requirements may lead to restrictions in gross vehicle weights and/or configurations. However, there are other road limitations that affect how the road may be used, for example, gradients, bends, narrow sections, bridges and culverts. These all have a direct impact on speed and safety, and hauliers and drivers must be given this information before operations start.

It is recommended that the expected 'performance' of the road be discussed before it is used, and contract conditions agreed to pre-empt damage on both public and forest roads.



The impacts of timber traffic on communities should be given consideration when planning haulage routes.

5.2 Driving

5.2.1 Safe driving

The haulier is responsible for providing drivers with adequate information, instruction and training and for monitoring driver behaviour, as well as making sure, with the driver, the safe condition and roadworthiness of their vehicle.

A comprehensive collection of information on safe driving is available from the Freight Transport Association (www.fta.co.uk) and the Road Haulage Association (www.rha.uk.net). Freight Best Practice (www.transportscotland.gov.uk/road) also includes a number of useful driver guides including; Bad Weather Driving Guide, Rural Driving Guide and the Driver Safety Guide.

5.3 Efficient driving

Fuel efficient driving is closely related to safe and courteous driving. There are clearly financial benefits from saving fuel, but reducing diesel consumption can also benefit the environment.

While modern engines are much cleaner than older ones, diesel fuel used in haulage is a source of greenhouse gases that contribute to global warming. All sectors of the economy are expected to contribute to national targets for reducing these emissions.

Growing trees and using wood products in place of more energy intensive materials can help reduce our overall emissions of greenhouse gases. There is therefore a particular incentive for the timber supply chain to demonstrate fuel efficiency and to highlight its low 'carbon footprint'.

There are a variety of training courses available on safe and fuel efficient driving that can contribute towards Driver CPC (Certificate of Professional Competence). The Timber Transport Forum has prepared training material on this subject, for timber hauliers, that can be delivered by driver trainers. There is also advice on 'measuring carbon footprints' from the Road Haulage Association (www.rha.uk.net) and Freight Transport Association (www.fta.co.uk).

REMEMBER

- ✓ Plan the route efficiently – avoid lost mileage and wasted fuel.
- ✓ Drive carefully – at a speed that is suitable for the road and weather conditions.
- ✓ Drive carefully to be safe, economical and courteous.
- ✓ Respect the community – show consideration for rural communities and road users.

6. Unloading timber

The requirements for unloading timber depend on how the timber will be unloaded and the site arrangements at processing plants, ports or railheads. Site-specific instructions will build on the general requirements given here.

The unloading site should have rules clearly displayed or drivers should be given a copy of the rules before they go to the unloading site, or both. Usually the site rules specify:

- use of personal protective equipment;
- safety distances and risk factors;
- stacking instructions;
- restrictions on staying in the cab during unloading and the policy on passengers and pets;
- speed limits and other restrictions on vehicle movements;
- smoking policy;
- responsibilities.

The site access, internal layout and exit should be well designed and easy for the driver to follow, including for instance:

- clear signs;
- a site plan (sign, map or both) with marked access to (for example) assistance, risk zones, first aid points and fire-fighting equipment;
- a clear driving route and unloading area with limited risk of conflicting operations.

The driver and others involved in the unloading operation should wear appropriate personal protective equipment including high-visibility clothing, hard hats and protective boots. Other personal protective equipment that is defined in the site-specific rules should be used or worn.



Site access should be well designed and easy for the driver to follow.

- Drivers must comply with the individual site rules and work to the site operator's instructions at all times.
- Compliance with rules and instructions should be monitored.
- Both the site operator and haulier are responsible for having an accident or damage reporting procedure.
- The loader should be positioned for safe and efficient unloading.

- Stabilisers should always be used when unloading with a vehicle-mounted loader.
- The loader and stow pins and bolsters should be carefully secured and all fixings checked before leaving.
- The vehicle should be cleaned of all debris in the designated area.
- Drivers unloading their vehicles must leave the stacks as instructed.
- Receiving staff must be properly trained to unload vehicles safely and avoid damage.

Unloading at the sawmill.
Receiving staff must be properly trained to unload safely.



Unloading must be accompanied by verifiable documents. There must be a system in place that provides drivers with a delivery advice note before leaving the forest. Drivers should have the correct paperwork to show the loaded weight at any point of the journey. When unloaded, they should receive a weight ticket or receipt that displays the load weight or the net vehicle weight.

REMEMBER

- ✓ Comply with site rules.
- ✓ Unload safely.
- ✓ Have the correct paperwork.

7. Improving roundwood haulage

7.1 Continuous improvement and co-operation

The Timber Transport Forum aims to facilitate co-operation across the industry for continuous improvement. The Forum's Technical Working Group advises on technical issues involved in continuous improvement and co-operation relating to timber haulage. Hauliers and their employers should contribute to continual improvement through regular discussions and agreement on follow-up measures and targets.

7.2 Communication

Co-operation relies on effective communication between those involved in timber transport and related operations. Take the time to establish working relations between all parties, share contact details and agree suitable means of prompt communication.

7.3 Training

Many organisations train drivers for large goods vehicle licences across the private sector, although most training is of a general nature. There is little organised training for loader operation in the transport of round timber, but generic loader operation training is available.

7.3.1 Driver Certificate of Professional Competence (CPC)

The Driver CPC (Certificate of Professional Competence) is for LGV and PCV drivers who drive professionally throughout the UK. It has been developed as a requirement of the EU Directive 2003/59, which is designed to improve the knowledge and skills of professional LGV drivers throughout their working life.

New Drivers: The Initial Qualification must be achieved by new LGV and PCV drivers along with their vocational licence to enable them to use their licence professionally.

Existing Drivers: Drivers who held a licence before 10 September 2009 are exempt from the initial CPC. This is known as 'acquired rights'.

All drivers, irrespective of when or how they obtained the Driver CPC must complete a total of 35 hours Periodic Training every five years to keep the Driver CPC valid. Drivers acquiring the Driver CPC via acquired rights will have to have completed their periodic training by the 9 September 2014.

Every training centre and course provided for Driver CPC has to be approved by JAUPT (Joint Approved Unit for Periodical Training). Make sure the driver training provider used for Driver CPC has JAUPT approved courses, or the training will be invalid and will not contribute towards Driver CPC.

The periodic training will require attendance at courses but will not require drivers to take or pass further examinations. See www.drivercpc-periodictraining.org for more information.

Some independent driver training providers across the country are developing 'timber specific' driver training courses for Driver CPC.

7.4 Biosecurity

There are an increasing number of pests and diseases of plants and trees, that could pose a threat to forests and woodlands if they were to become established in Great Britain. Good biosecurity practice means working in a way that minimises the risk of contamination and the spread of pests and diseases.

Pest and disease outbreaks can have a severe economic impact on forestry and related industries. They can cause financial loss, and have a major impact on other sectors, such as wood processing and tourism. The spread of endemic pests, while less newsworthy, can have an equally detrimental impact.

The forestry sector encourages good biosecurity practice by all persons entering or working in forests and woodlands and we encourage hauliers to lead by example.

Loads leaving the forest should be free of debris and brash and processing plants should have a designated area suitable for drivers to clean down their vehicles. Where cleaning operations involve working at height or the use of compressed air, a risk assessment may be required.

Supporting documents

Freight Transport Association
www.fta.co.uk

Road Haulage Association
www.rha.uk.net

AFAG Guide 703 Debogging and Recovery of Forestry Machines
www.hse.gov.uk/pubns/forindex.htm

The Work at Height Regulation 2005
www.hse.gov.uk/pubns/indg401.pdf

AFAG Guide 804 Electricity at Work – Forestry and Arboriculture
www.hse.gov.uk/pubns/afag804.pdf

UK Forestry Standard Guidelines on Forests and Water
www.forestry.gov.uk/ukfs/water

Five Steps to Risk Assessment
www.hse.gov.uk/pubns/indg163.pdf

SAFED for HGVs
Innovation in Scottish Timber Haulage: Tyre pressure control systems
Rural Driving Guide
Bad Weather Driving Guide
www.transportscotland.gov.uk/road/policy/freight/best-practice

HSE – Managing Health and Safety in Forestry.
www.hse.gov.uk/pubns/indg294.pdf

Appendix 1

A1.1 Maximum weights for artics and drawbar combinations

A= Distance between the rear axle of the lorry and the front axle of the trailer is not less than 3 m.

B= 2 axle tractor unit and 2 axle trailer, the tractor unit does not exceed 18000, the trailer axle weights do not exceed 20000 kg in total and the drive axle is fitted with twin tyres and road friendly suspension.

C= Axle weight of each drive axle does not exceed 10500 kg. Trailer limited to a maximum of 24000 kg and each trailer axle has road friendly suspension. Each vehicle in the combination has at least 3 axles and EITHER each drive axle is fitted with twin tyres and road friendly suspension OR each drive axle which is not a steering axle is fitted with twin tyres and the axle weight does not exceed 8500 kg.

D= Complies with (C) and the tractor unit is fitted with a Euro II or Euro III emission standard low pollution engine. For operations over 41 000 kg the motor vehicle must be fitted with an engine meeting at least Euro II standard or be fuelled by gas.

Vehicle type	Number of axles	Maximum weight (kg)
Articulated vehicle	3	26 000
Rigid lorry + trailer	3	22 000
Rigid lorry + trailer A	3	26 000
Articulated vehicle	4	36 000
Articulated vehicle B	4	38 000
Rigid lorry + trailer	4	30 000
Rigid lorry + trailer A	4	36 000
Articulated vehicle	5 or more	40 000
Rigid lorry + trailer	5 or more	34 000
Rigid lorry + trailer A	5 or more	40 000
Articulated vehicle C	6 or more	41 000
Rigid lorry + trailer A/C	6 or more	41 000
Articulated vehicle D	6 or more	44 000
Rigid lorry + trailer A/D	6 or more	44 000

A1.2 Maximum weight for rigids

A= Each driving axle which is not a steering axle is fitted with twin tyres and road-friendly suspension, OR each drive axle has twin tyres and the maximum weight for each axle does not exceed 9500 kg.

Vehicle type	Number of axles	Maximum weight (kg)
Rigid motor vehicle	2	18 000
Drawbar trailer (excluding centre axle trailer)	2	18 000
Drawbar trailer (excluding centre axle trailer)	3 or more	24 000
Rigid motor vehicle	3	25 000
Rigid motor vehicle A	3	26 000
Rigid motor vehicle	4 or more	30 000
Rigid motor vehicle A	4 or more	32 000

A1.3 Maximum overall lengths

Overall length for artics

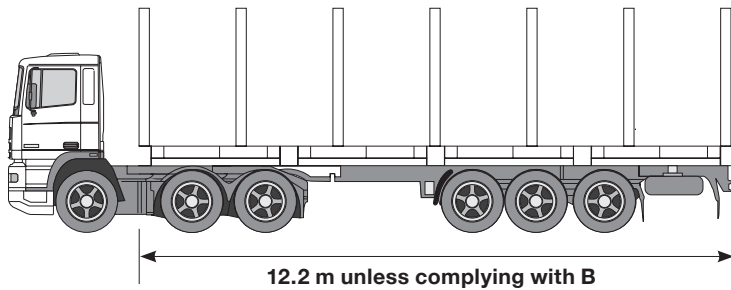

A = 15.5 m
B = 16.5 m if kingpin to rear of trailer does not exceed 12 m and no part of the trailer is outside 2.04 m radius in front of the Kingpin.

Overall length for drawbar

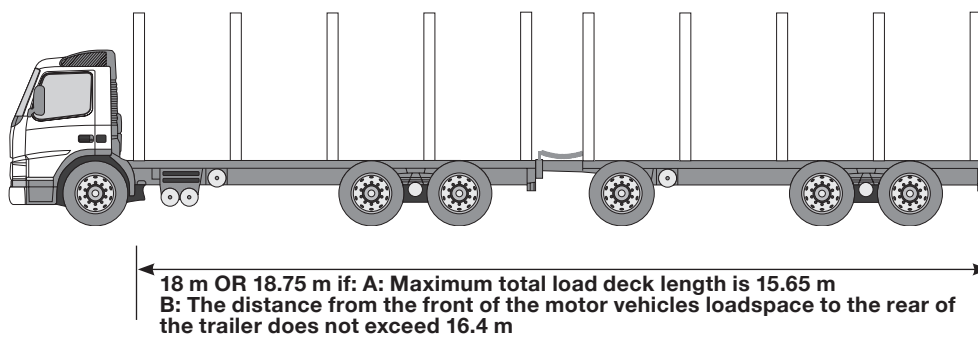

Overall length for rigid lorries

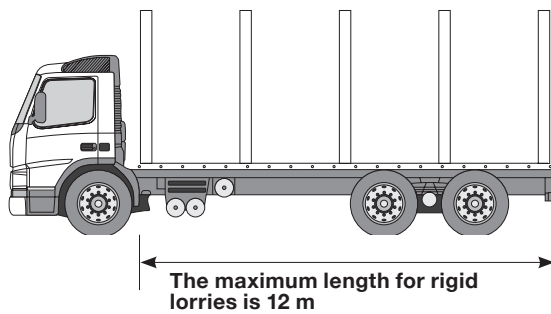

Overhanging load restrictions

The table below sets out the requirements for loads that overhang the rear of vehicles. Further information on loads that overhang the front, rear or sides of vehicles can be found on the Department for Transport website www.dft.gov.uk/pgr/roads/vehicles/vssafety/info-overhangingloads.pdf.

Projection	Requirement
<1 m	No marking.
>1 m but not exceeding 2 m	Marked to be clearly visible.
>2 m but not exceeding 3.05 m	Approved end marker board indirectly illuminated at night and attendant carried in lorry.
>3.05 m	Approved side and end marker boards indirectly illuminated at night, police notification and attendant carried in lorry.

Appendix 2

A2.1 Effective signs for forest operations

Forestry Commission Scotland
Coimisean na Coilltearachd Alba

Forest operations in this forest

Our forests and woods are open to all, in line with our open access policy. However, you should be aware that forest operations are currently taking place in this forest. Where necessary, diversions or closures have been put in place to ensure your safety.

Please:

- do not approach machinery
- do not climb on timber stacks
- follow the diversion and safety signs

We apologise for any inconvenience.

Look out for these signs around the forest

		
Warning Forest operations Please follow all signs and diversions	No unauthorised persons allowed beyond this point	Do not climb on timber stacks

Forest District name
Tel: 0000 000000 www.forestry.gov.uk/scotland

Forestry Commission Scotland
Coimisean na Coilltearachd Alba



Warning Forest operations

Please follow all signs and diversions
We apologise for any inconvenience

Forest District name
Tel: 0000 000000 www.forestry.gov.uk/scotland

Forestry Commission Scotland
Coimisean na Coilltearachd Alba



Do not climb on timber stacks

Forest District name
Tel: 0000 000000 www.forestry.gov.uk/scotland

Forestry Commission Scotland
Coimisean na Coilltearachd Alba



No unauthorised persons allowed beyond this point

Forest District name
Tel: 0000 000000 www.forestry.gov.uk/scotland

Example road defect report

Road defect report

Forest district:

Tel:

Fax:

Email:

Forest:

Road class and type (for example, picnic site or car park):

Road segment numbers (if known) or name:

Defect:

.....

.....

.....

.....

.....

Reference/incident number:

Priority: High Medium Low Temporary closure*

Reported by:

Date:

Do you want to know the priority level and/or, when the defect is repaired? Yes No

Contact address:

Tel:

Email:

*See notes: to be assessed by forest district or civil engineering staff.

TimberTransportForum

delivering solutions for a growing UK harvest

www.timbertransportforum.co.uk